



Linear Regulator Output Structures

Kieran O'Malley
 ON Semiconductor
 2000 South County Trail
 East Greenwich, RI 02818

APPLICATION NOTE

Choosing a linear regulator for an application involves more than looking for the part with the lowest dropout voltage or lowest cost. Although IC manufacturers promote regulators with very low dropout voltages, these are often the most expensive part in their product line and not necessarily the best solution. By considering system specifications such as minimum and maximum input voltage, load current and system cost, a designer can choose the best regulator for an application.

This application note reviews the three bipolar output structures found in most linear regulators. The advantages, disadvantages and reasons for using certain output stages in certain situations are discussed. Throughout the article, design examples are provided to illustrate the process of selecting the right output structure for a given set of system conditions.

Introduction

Some designers classify linear regulators by their output structure or pass device. Output structures can be either a bipolar or a FET transistor. The majority of the regulator market uses bipolar outputs and we will restrict our discussion to them. The bipolar output structure is either a simple darlington NPN, a low dropout PNP, or a composite NPN-PNP device. Bipolar regulators are available in a variety of output voltages and options and they are usually less expensive than the FET devices.

The output structure is a critical factor in system design because it determines the regulator's dropout voltage ($V_{Dropout}$), quiescent current drain, power dissipation, output compensation circuitry and protection requirements.

NPN Output Structures

Figure 1 shows the output stage of the older, conventional linear regulators with their darlington NPN output stage as represented by the LM78XX series. The dropout voltage for these types of regulators is the sum of the V_{CE} for the PNP transistor plus the V_{BE} of each NPN transistor or

$$2.0 V_{BE(NPN)} + V_{CE(sat)} \approx 2.0 V$$

The inputs to the error amplifier are a reference voltage, V_{REF} and a sample of the output voltage, V_{OUT} . The error amplifier controls the bias current for the PNP transistor, which in turn controls the drive current to the darlington pair. The darlington pair acts as a variable resistor in series with the output load.

The error amplifier along with the PNP and the darlington pair minimize the fluctuations in V_{OUT} as it responds to changing V_{IN} and load current conditions. If the input voltage (V_{IN}) increases or the output current drops due to changing load conditions, the output voltage will attempt to rise. In response, the voltage at the non inverting terminal of the error amplifier increases, reducing the bias for the PNP transistor. There will follow an increase in the apparent resistance of the darlington pair and a concomitant reduction in output voltage.

Conversely, if the output voltage tries to decrease, the output of the error amplifier will decrease, the PNP bias current increases and the bias current of the darlington pair will increase forcing the output voltage higher.

The main advantage of the NPN darlington architecture is its ability to pass high currents ($> 1.0 A$) while using relatively low bias current. (The bias current is one component of the device's quiescent current, I_Q .)

As indicated in Figure 1, the base current from the PNP transistor flows to ground while the bulk of the bias current

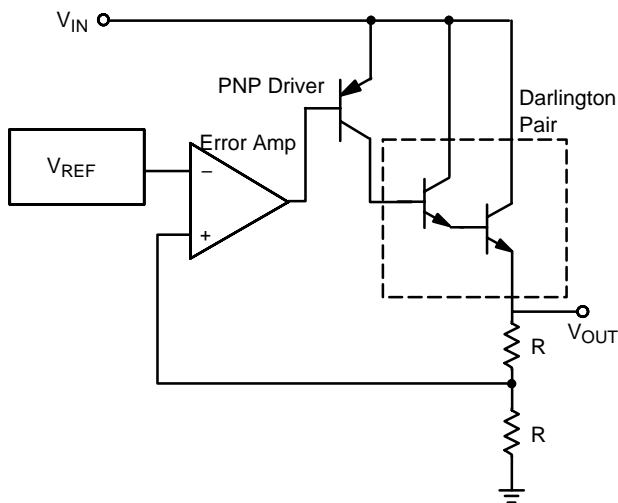

Figure 1. Typical NPN Output Structure for an NPN Linear Regulator

for the darlington pair flows to the load. This bias current is the load current divided by the gain of the NPN darlington and PNP transistor composite or I_{LOAD}/β^3 .

The NPN darlington output stage is still quite widely used. It is the least expensive of the three bipolar types. Its output circuitry occupies the smallest area on chip, and it often only requires a small compensation capacitor which in most cases, is integrated on chip. (Occasionally an application with a rapidly changing dynamic load will require an external capacitor. In these cases, the capacitor damps the regulator's fast output response and prevents output voltage overshoot.)

The NPN output structure has two main disadvantages: it has a large dropout voltage (≈ 2.0 V) and it lacks reverse battery protection. However if low dropout voltage is not a primary concern, and the system does not require reverse battery protection, the NPN output structure is the topology of choice in an application.

PNP Output Structures

The PNP low dropout architecture is a more recent and popular output structure in linear regulators. The PNP pass device is driven directly by the output of the error amplifier (Figure 2). The dropout voltage is simply the $V_{CE(sat)}$ of the PNP transistor (100 mV to 600 mV, typ) which is a function of load current and operating temperature.

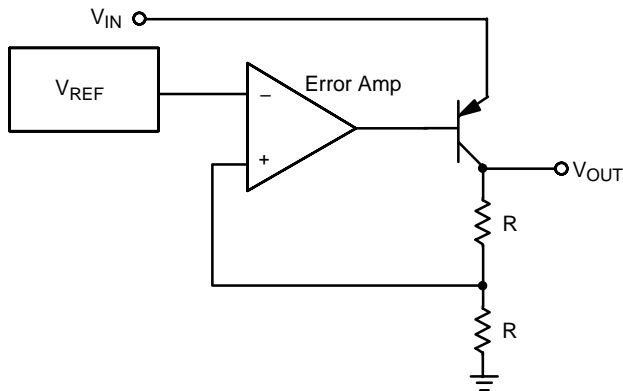

Figure 2. Typical PNP Output Structure for a Low Dropout Regulator

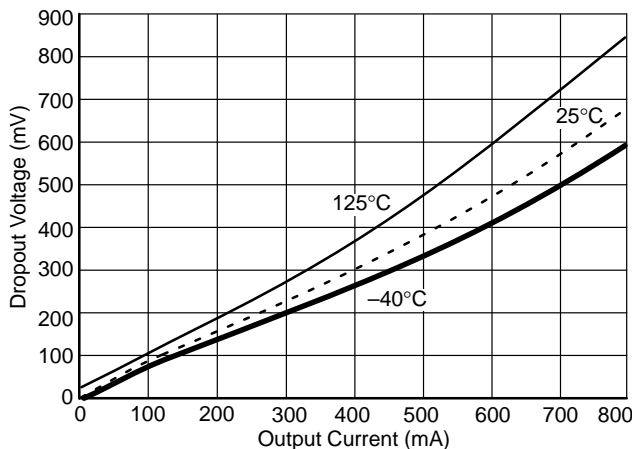

Figure 3. PNP Dropout Voltage as a Function of Output Current and Temperature for the CS8129

Most manufacturers provide graphs of the dropout voltage as a function of load current and temperature in their data sheets (Figure 3, CS8129). When determining the minimum battery voltage for a low dropout system, consider the worst case system conditions; i.e. highest operating temperature and maximum load current. Use these values to calculate the minimum battery voltage under which the regulator will operate. For example, assume the maximum regulator load current is 600 mA at 125°C.

According to Figure 3, the typical dropout voltage would be 600 mV. The minimum battery voltage needed to provide a 5.0 V regulated supply would be

$$V_{battery(min)} = V_{dropout} + 5.0 V$$

$$= 600 \text{ mV} + 5.0 \text{ V} = 5.6 \text{ V}$$

The PNP output structure offers two advantages over either the darlington NPN or the composite NPN-PNP outputs. It has a very low dropout voltage and inherent reverse battery protection. The low dropout voltage lets the regulator remain in regulation longer as the battery voltage decays with use. This phenomenon “extends” the battery life of the system. The PNP’s base-emitter junction protects against reverse battery damage.

Low dropout PNP regulators have three main disadvantages: a relatively high quiescent current (the bias current of the PNP pass transistors flows to ground not out to the load), an output that requires a large external compensation capacitor, and a larger die size that raises the device’s cost.

The PNP’s higher quiescent current means that more power (heat) must be dissipated in the regulator.

Power dissipation, P_D , for any linear regulator consists of two terms, one for the output stage and the other for the remaining internal circuitry or

$$P_D = (V_{IN} - V_{OUT})I_{LOAD} + V_{IN}I_Q \quad (1)$$

The second term in the equation contains the I_Q term. Under high input voltage and load current conditions, the second term in equation 1 may dominate and force the use of a more expensive power package and a heat sink where either of the other two bipolar output types with their lower I_Q 's would not.

The other drawback to using a PNP regulator is the need for a large ($\approx 10 \mu\text{F}$) external compensation capacitor on the output to ensure stability. The PNP transistor introduces a pole in the regulator loop at approximately 200 kHz – much too low a frequency for compensation by an integrated capacitor. (For more information see the ON Semiconductor applications note, “Compensation for Linear Regulators,” document number SR003AN/D, available through the Literature Distribution Center or via our website at <http://www.onsemi.com>.) This capacitor adds cost to the system.

Finally, a PNP transistor occupies more die area to pass the same amount of current as an NPN transistor. Due to the fact that bipolar processes are optimized around the NPN device, leaving the PNP with a substantially lower area

efficiency. Some area savings can be salvaged by using a vertical rather than a horizontal PNP but the pass device is still larger than its NPN counterpart.

Composite NPN/PNP Output Structures

The third type of bipolar linear regulator and the most recently developed, is a compromise between the NPN and the PNP regulators. It is known as a composite, quasi-low dropout or compound output structure. Figure 4 shows the basic structure. The pass device is a single power NPN transistor, driven by a PNP transistor. The total dropout voltage is

$$V_{BE}(NPN) + V_{CE(sat)}(PNP) \approx 1.25 \text{ V}$$

or approximately half way between the dropout for an NPN (2.0 V) and a PNP (0.600 V) regulator.

This structure eliminates one of the V_{BE} drops that contributes to the large dropout of the NPN regulator and takes up less die area than the pass device in the PNP regulator.

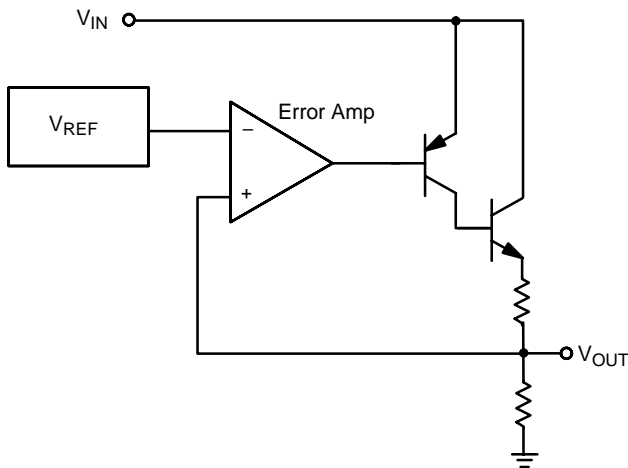

Figure 4. NPN/PNP Output Structure for Composite Linear Regulator

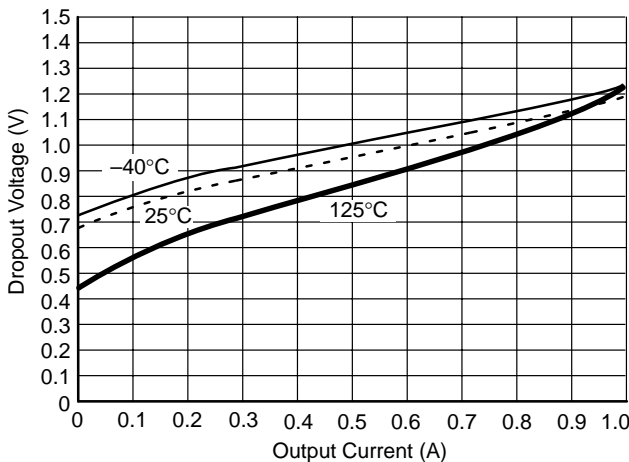

Figure 5. Dropout Voltage as a Function of Output Current and Temperature for the Composite Output Stage of the CS8121

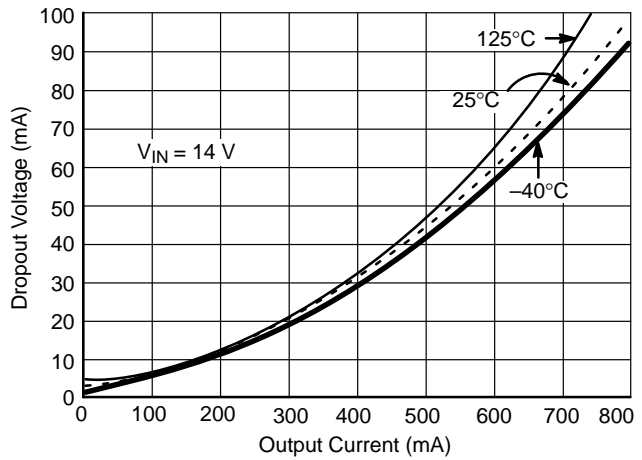

Figure 6. Quiescent vs. Output Current for the CS8129

The composite regulator’s bias current for the output stage is equal to I_{LOAD}/β^2 , making it more efficient than its PNP counterpart. In the composite structure, the base drive of the NPN pass transistor flows into the load and only the smaller bias current for the PNP flows to ground.

The dropout voltage of the composite regulator also varies as a function of load current (see Figure 5) because the V_{BE} of the pass transistor dominates the dropout voltage. This variation must be kept in mind as one calculates minimum battery voltage and package choice for the application.

The composite regulator does not have inherent reverse battery protection and, like the PNP regulator, it requires a large external capacitor for output stability.

Output Structures and System Efficiency

To illustrate the impact of quiescent current on efficiency, let’s compare a typical PNP with a composite NPN/PNP regulator. In this application, the linear regulator must deliver 400 mA at 5.0 V up to an ambient operating temperature of 85°C. V_{IN} to the regulator is 8.0 V. Consulting the Output vs. Quiescent Current graph for the CS8129, Figure 6, we find that for this load current, the quiescent current is 30 mA. Substituting these numbers into the power dissipation equation we get

$$P_D = (8.0 \text{ V} - 5.0 \text{ V})400 \text{ mA} + (8.0 \text{ V})30 \text{ mA}$$

$$= 1.20 + 0.24 = 1.44 \text{ Watts}$$

A regulator’s efficiency is calculated as

$$\text{Efficiency} = \frac{P_{OUT}}{P_{IN}} \times 100\% \tag{2}$$

$$= \frac{V_{OUT}I_{LOAD}}{V_{IN}(I_Q + I_{LOAD})} \times 100\%$$

The efficiency of the CS8129 regulator under these conditions is

$$\text{Efficiency} = \frac{5.0 \text{ V} \times 400 \text{ mA}}{8.0 \text{ V} \times 430 \text{ mA}} \times 100\% = 58\%$$

By comparison, the composite NPN/PNP regulator, CS8121, has a power dissipation of

$$P_D = (8.0 \text{ V} - 5.0 \text{ V})400 \text{ mA} + (8.0 \text{ V})2.0 \text{ mA} \\ = 1.200 + 0.016 = 1.216 \text{ Watts}$$

and an efficiency of

$$\frac{5.0 \text{ V} \times 400 \text{ mA}}{8.0 \text{ V} \times 402 \text{ mA}} \times 100\% = 62\%$$

Further analysis of package heat handling capabilities will reveal whether these regulators require a heatsink in a particular package. But even if both could operate in the same type of package without the added expense of a heatsink, the PNP still remains the least efficient of the two, consuming more power to produce the same output power as the composite regulator.

Output Structures and Package Selection

Package selection is determined by the power that the circuit must dissipate, the thermal characteristics of the package, and the ambient temperature of the system. These three factors are related by the equation

$$P_D = \frac{T_{J \text{ max}} - T_{A \text{ max}}}{R\theta_{JA}}$$

where $T_J = 150^\circ\text{C}$ is usually specified by IC manufacturers, $T_{A \text{ max}}$ is the maximum ambient temperature of the application and $R\theta_{JA}$ is the thermal rating of the package as reported in the packaging section of the data sheet.

The TO-220 package has an $R\theta_{JA}$ of 50°C/W . With a $T_{A \text{ max}}$ of 85°C , the maximum P_D for the TO-220 will be

$$P_D = \frac{150^\circ\text{C} - 85^\circ\text{C}}{50^\circ\text{C/Watt}} = 1.3 \text{ Watts}$$

Looking at the P_D 's of the two regulators cited above, it's clear that the composite regulator ($P_D = 1.216 \text{ Watts}$) will operate in a TO-220 power package but the PNP regulator ($P_D = 1.44 \text{ Watts}$) will require additional heat sinking in that same package. For additional information on Thermal Management see the application note AND8036/D, available through the Literature Distribution Center or via our website at <http://www.onsemi.com>. A heat sink will add cost and inventory to the system. Here again, if low dropout

is not a critical requirement, the composite regulator is the better choice.

Summary

A summary of the different output structure advantages and disadvantages is presented in Table 1. If low dropout is the driving requirement for a system, a PNP output structure is a necessity. If price pressures are the critical concern, an NPN output stage should be your first consideration.

Table 1. Summary of Output Structure Advantages and Disadvantages

Output Structure	Advantages	Disadvantages
NPN	<ul style="list-style-type: none"> smallest die size fastest transient response small compensation capacitor 	<ul style="list-style-type: none"> large dropout voltage no reverse battery protection
PNP	<ul style="list-style-type: none"> low dropout voltage reverse battery protection 	<ul style="list-style-type: none"> high quiescent current large compensation capacitor large die size
Composite NPN/PNP	<ul style="list-style-type: none"> moderate dropout voltage lower quiescent current than PNP 	<ul style="list-style-type: none"> large compensation capacitor no reverse battery protection

Table 2 gives the main performance parameters for the representative devices with NPN, PNP and NPN/PNP output structures.

Table 2. Performance Comparison for Three Bipolar Output Structures @ 5.0 V 500 mA @ 25°C

Regulator P/N	Output Structure	Dropout (typ)	IQ (typ)
LM109	NPN	1.6 V	5.15 mA
CS8129	PNP	0.37 V	45 mA
CS8121	Composite	0.95 V	2.5 mA

The NPN and the PNP regulators have widely different dropout voltage and quiescent current values. The composite regulator's dropout voltage lies in between the NPN and PNP regulators while its quiescent current is much closer to that of the NPN regulator.

Notes

Notes

Notes

SMART REGULATOR is a registered trademark of Semiconductor Components Industries, LLC (SCILLC).

ON Semiconductor and  are trademarks of Semiconductor Components Industries, LLC (SCILLC). SCILLC reserves the right to make changes without further notice to any products herein. SCILLC makes no warranty, representation or guarantee regarding the suitability of its products for any particular purpose, nor does SCILLC assume any liability arising out of the application or use of any product or circuit, and specifically disclaims any and all liability, including without limitation special, consequential or incidental damages. "Typical" parameters which may be provided in SCILLC data sheets and/or specifications can and do vary in different applications and actual performance may vary over time. All operating parameters, including "Typicals" must be validated for each customer application by customer's technical experts. SCILLC does not convey any license under its patent rights nor the rights of others. SCILLC products are not designed, intended, or authorized for use as components in systems intended for surgical implant into the body, or other applications intended to support or sustain life, or for any other application in which the failure of the SCILLC product could create a situation where personal injury or death may occur. Should Buyer purchase or use SCILLC products for any such unintended or unauthorized application, Buyer shall indemnify and hold SCILLC and its officers, employees, subsidiaries, affiliates, and distributors harmless against all claims, costs, damages, and expenses, and reasonable attorney fees arising out of, directly or indirectly, any claim of personal injury or death associated with such unintended or unauthorized use, even if such claim alleges that SCILLC was negligent regarding the design or manufacture of the part. SCILLC is an Equal Opportunity/Affirmative Action Employer.

PUBLICATION ORDERING INFORMATION

Literature Fulfillment:

Literature Distribution Center for ON Semiconductor
P.O. Box 5163, Denver, Colorado 80217 USA
Phone: 303-675-2175 or 800-344-3860 Toll Free USA/Canada
Fax: 303-675-2176 or 800-344-3867 Toll Free USA/Canada
Email: ONlit@hibbertco.com

N. American Technical Support: 800-282-9855 Toll Free USA/Canada

JAPAN: ON Semiconductor, Japan Customer Focus Center
4-32-1 Nishi-Gotanda, Shinagawa-ku, Tokyo, Japan 141-0031
Phone: 81-3-5740-2700
Email: r14525@onsemi.com

ON Semiconductor Website: <http://onsemi.com>

For additional information, please contact your local Sales Representative.